

Industrial Batteries / Network Power  
**Sonnenschein PowerCycle**

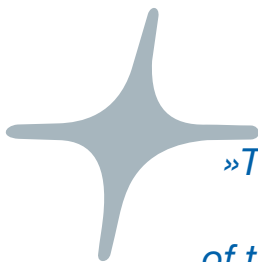

»The latest advancement  
 proving the superiority  
 of the **dryfit<sup>®</sup>** technology«

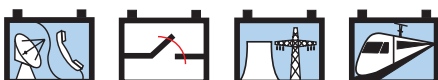

**PowerCycle**

# Sonnenschein PowerCycle

## Technical data, Applications, Dimensions

### Applications

The dryfit Gel battery offers excellent performance in a variety of applications and is well suited to areas where the power supply is unstable and harsh outdoor environments are prevalent.

### Your benefits:

- > Advanced grid design for Longer Life at high temperatures – low operating costs
- > Fast Charging – high availability
- > Exceptional cyclic performance: 1,600 cycles at 60% depth of discharge
- > Optimized for PSOC (Partial State of Charge) operation, to increase the cycle life
- > Durable Polypropylene container
- > Front Terminal design with handles - Easy installation and maintenance
- > Lowest energy consumption
- > Maintenance free – no topping-up
- > Proof against deep discharge
- > The latest advancement based on the wellproven dryfit® Gel technology, this new and innovative battery is the perfect fit for applications with unreliable mains and harsh environments



### Technical characteristics and data

Type	Part number	Nom. voltage	Capacity C <sub>100</sub> 1.80 Vpc 20°C	Capacity C <sub>10</sub> 1.80 Vpc 20°C	Capacity C <sub>1</sub> 1.80 Vpc 20°C	Length max	Width max.	Height max.	Weight approx.	Terminal
		V	Ah	Ah	Ah	mm	mm	mm	kg	
PC12/180 FT	NGPC120180HS0MA	12	180	165	114	568	128	320	58.4	M-M8-45°

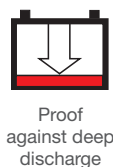
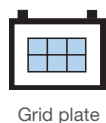
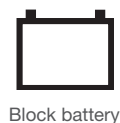
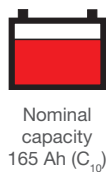

# Sonnenschein PowerCycle

## Constant current and constant discharge

### Discharge in A at 20°C

V <sub>pc</sub>	5 Min	10 min	15 min	20 min	30 min	45 min	1 h	2 h	3 h	4 h	5 h	8 h	10 h	20 h
1.90	181	172	161	152	128	103	88.6	56.5	40.8	32.4	27.4	18.0	14.7	7.76
1.87	211	202	186	171	144	114	94.9	60.0	43.0	34.0	28.8	18.9	15.5	8.19
1.85	240	221	199	179	152	118	98.8	61.8	44.2	34.9	29.4	19.3	15.9	8.39
1.83	265	241	215	189	158	122	101	63.1	45.1	35.5	29.9	19.7	16.1	8.58
1.80	289	261	229	202	164	127	104	64.7	46.1	36.2	30.3	20.0	16.5	8.75
1.77	312	278	243	212	170	130	107	65.8	46.8	36.7	30.5	20.3	16.7	8.89
1.75	327	291	254	219	173	132	108	66.4	47.2	37.0	30.7	20.4	16.9	8.95
1.73	343	304	264	225	177	134	110	67.0	47.5	37.3	30.9	20.5	16.9	8.95
1.70	363	318	270	232	181	136	111	67.6	47.9	37.6	31.1	20.7	16.9	8.95
1.67	386	325	277	238	184	138	112	68.1	48.2	37.8	31.1	20.7	16.9	8.95
1.65	408	330	282	242	187	139	113	68.4	48.4	37.8	31.1	20.7	16.9	8.95
1.60	432	343	291	248	191	142	114	68.7	48.5	37.9	31.1	20.7	16.9	8.95

### Discharge in Watt/block at 20°C

V <sub>pc</sub>	5 Min	10 min	15 min	20 min	30 min	45 min	1 h	2 h	3 h	4 h	5 h	8 h	10 h	20 h
1.90	2172	2079	1961	1845	1523	1209	977	631	468	367	304	203	166	87
1.87	2553	2431	2256	2089	1642	1306	1048	668	494	387	320	213	174	92
1.85	2912	2736	2493	2220	1729	1352	1090	690	510	398	329	219	179	95
1.83	3207	2918	2640	2327	1800	1382	1125	708	522	408	337	224	183	98
1.80	3474	3139	2786	2456	1884	1416	1164	760	536	418	345	228	187	100
1.77	3688	3276	2880	2529	1930	1435	1184	766	542	423	348	230	189	102
1.75	3818	3348	2933	2571	1957	1450	1196	769	546	425	350	232	190	102
1.73	4019	3496	2974	2601	1976	1462	1205	772	549	427	352	232	190	102
1.70	4248	3622	3025	2641	2002	1478	1217	775	552	430	354	234	190	102
1.67	4419	3694	3054	2672	2022	1491	1228	778	555	432	354	234	190	102
1.65	4596	3795	3087	2689	2034	1498	1235	779	556	432	354	234	190	102
1.60	4796	3864	3128	2722	2057	1513	1250	783	557	433	354	234	190	102

### Drawings with terminal position, terminal and torque

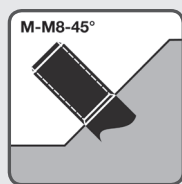
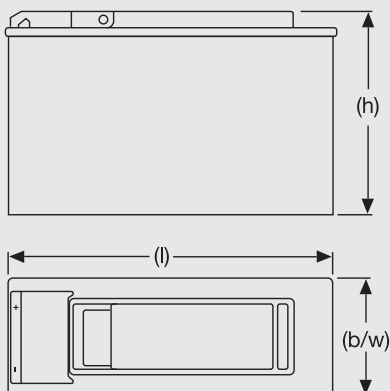

8 Nm

Not to scale!





**Exide Technologies**, with operations in more than **80 countries**, is one of the world's largest producers and recyclers of lead-acid batteries. Exide Technologies provides a comprehensive and customized range of stored electrical energy solutions. Based on **over 100 years of experience** in the development of innovative technologies, Exide Technologies is an esteemed partner of OEMs and serves the spare parts market for industrial and transportation applications.

**GNB® INDUSTRIAL POWER** – A division of Exide Technologies – offers an **extensive range of storage products and services**, including solutions for telecommunication systems, railway applications, mining, photovoltaic (solar energy), uninterrupted power supply (UPS), electrical power generation and distribution, fork lifts and electric vehicles.

**Exide Technologies** takes pride in its commitment to a better **environment**. Its Total Battery Management programme, (an integrated approach to manufacturing, distributing and recycling of lead-acid batteries), has been developed to ensure a safe and responsible life cycle for all of its products.



»The **next Level** of  
**Energy Management**«

**GNB® INDUSTRIAL POWER** provides long lasting energy concepts that combine efficiency with flexibility.